

BALDOR® • RELIANCE 

Product Information Packet

ECP64104TR-4

30HP,1770RPM,3PH,60HZ,286T,1060M,TEFC,F1

Part Detail							
Revision:	K	Status:	PRD/A	Change #:		Proprietary:	No
Type:	AC	Elec. Spec:	10WGZ438	CD Diagram:	CD0006	Mfg Plant:	
Mech. Spec:	10J448	Layout:	10LYJ448	Poles:	04	Created Date:	11-04-2015
Base:	RG	Eff. Date:	02-12-2018	Leads:	3#10		

Specs			
Catalog Number:	ECP64104TR-4	Inverter Code:	Inverter Duty
Enclosure:	TEFC	KVA Code:	G
Frame:	286T	Lifting Lugs:	Standard Lifting Lugs
Frame Material:	Iron	Locked Bearing Indicator:	Locked Bearing
Output @ Frequency:	30.000 HP @ 60 HZ	Motor Lead Quantity/Wire Size:	3 @ 10 AWG
Synchronous Speed @ Frequency:	1800 RPM @ 60 HZ	Motor Lead Exit:	Ko Box
Voltage @ Frequency:	460.0 V @ 60 HZ	Motor Lead Termination:	Ring Terminals
XP Class and Group:	CLI GP A,B,C,D	Motor Type:	1060M
XP Division:	Division II	Mounting Arrangement:	F1
Agency Approvals:	UR	Power Factor:	84
	CSA EEV	Product Family:	Chem Process S/P 32-8 IEEE 841
	CSA	Pulley End Bearing Type:	Roller
Auxillary Box:	No Auxillary Box	Pulley Face Code:	Standard
Auxillary Box Lead Termination:	None	Pulley Shaft Indicator:	Standard
Base Indicator:	Rigid	Rodent Screen:	None
Bearing Grease Type:	Mobilith SHC220, HC9455	Shaft Extension Location:	Pulley End
Blower:	None	Shaft Ground Indicator:	No Shaft Grounding
Constant Torque Speed Range:	1.0	Shaft Rotation:	Reversible

Current @ Voltage:	36.000 A @ 460.0 V	Shaft Slinger Indicator:	No Slinger
Design Code:	B	Speed Code:	Single Speed
Drip Cover:	No Drip Cover	Motor Standards:	NEMA
Duty Rating:	CONT	Starting Method:	Direct on line
Electrically Isolated Bearing:	Not Electrically Isolated	Thermal Device - Bearing:	NONE (OLD)
Feedback Device:	NO FEEDBACK	Thermal Device - Winding:	None
Front Face Code:	Standard	Vibration Sensor Indicator:	No Vibration Sensor
Front Shaft Indicator:	None	Winding Thermal 1:	None
Heater Indicator:	No Heater	Winding Thermal 2:	None
Insulation Class:	F	XP Temp Code:	T3C

Nameplate NP3201									
STK.NO.	ECP64104TR-4	P/N		ENCL	TEFC				
SPEC.	10J448Z438	CC	010A	FRAME	286T	S/N			
HP	30	CLASS	F	HZ	60	ODE BRG	6311	DE BRG	NU311
RPM	1770	RPM MAX	2700	PH	3	DES	B	D.E. BRG.	55RU03X30X
VOLT	460	CODE	G	O.D.E. BRG.	55BC03X30X				
AMP	36	MOTOR WEIGHT	460	GREASE	MOBILITH SHC220				
RATING	40C AMB-CONT	MAX. KVAR	7.7	BLANK	AIR COOLED HEAT				
NEMA-NOM-EFF	93.6	# OF ROTOR BARS	40	SER.F.	1.15	IP	56	EXCHANGER MTR	
G.MIN.EFF	92.4	# OF STATOR SLOTS	48	PF	84	INV.TYPE	PWM		
TEMP CODE	T3C	INVERTER-TEMP-CODE	180						
TEMP =	160	C HP FR	60	C HP TO	90				
CT HZ FROM	1.0	CT HZ TO	60						
HTR-VOLTS		HTR-AMPS		HTR-WATTS		MAX. SPACE HEATER TEMP.		VT HZ FROM	0
								VT HZ TO	60

Parts List		
Part Number	Description	Quantity
SA310041	SA 10J448Z438	1.000 EA
RA297416	RA 10J448Z438	1.000 EA
09FN3001D02	EXTERNAL FAN, PLASTIC	1.000 EA
WD1000B16	T&B CX70TN TERMINAL	1.000 EA
10XN2520K06	1/4-20 X 3/8" HX HD SCREWGRADE 5, ZINC P	1.000 EA
10CB1000A09P	CONDUIT BOX, MACH W/EPOXY PRIMER	1.000 EA
09GS1010	GASKET, DWG, LEADWIRE SEPERATOR	1.000 EA
10XN3118K16	5/16-18 X 1' GRADE #5, STL, ZINC PLATE	4.000 EA
HW1001A31	LOCKWASHER 5/16, ZINC PLT.591 OD, .319 I	4.000 EA
WD1000B16	T&B CX70TN TERMINAL	1.000 EA
10XN2520K06	1/4-20 X 3/8" HX HD SCREWGRADE 5, ZINC P	1.000 EA
HW1001A25	LOCKWASHER 1/4, ZINC PLT .493 OD, .255 I	1.000 EA
HW4500A20	1/8NPT SL PIPE PLUG	1.000 EA
10XN3816K28	3/8-16 X 1.75 HEX HD CAP SCREW, GRADE 5	4.000 EA
HW1001A38	LOCKWASHER 3/8, ZINC PLT .688 OD, .382 I	4.000 EA
HA4017A02	.125X2.50 GREASER EXTENS.F/S	2.000 EA
HW4019A01	PIPE COUPLING 1/8 NPT,STEEL,ZINC COATING	1.000 EA
HW4601A53	INPRO/SEAL VBXX FOR 311 BEARING/310 FRAM	1.000 EA
10XN3118K40	5/16-18 X 2.50" HEX HD, GRADE 5	4.000 EA
HW4600G54	DOME SLINGER, 7.125 OD X 1.870/1.810 ID	1.000 EA
10EP1110A123P	MACH'D W/EPOXY PRIMER	1.000 EA
HW4500A20	1/8NPT SL PIPE PLUG	1.000 EA
10XN3816K28	3/8-16 X 1.75 HEX HD CAP SCREW, GRADE 5	4.000 EA
HW1001A38	LOCKWASHER 3/8, ZINC PLT .688 OD, .382 I	4.000 EA

Parts List (continued)		
Part Number	Description	Quantity
HW4601A53	INPRO/SEAL VBXX FOR 311 BEARING/310 FRAM	1.000 EA
10XN3118K40	5/16-18 X 2.50" HEX HD, GRADE 5	4.000 EA
WD4100A08	HEYCO #2783 DOME PLUG DP-2000(CUSTOME	1.000 EA
10XN3118K16	5/16-18 X 1' GRADE #5, STL, ZINC PLATE	3.000 EA
HW1001A31	LOCKWASHER 5/16, ZINC PLT.591 OD, .319 I	3.000 EA
10CB1503A01P	CONDUIT BOX LIPPED LID, MACH W/EPXY PRMR	1.000 EA
14GS1003	GASKET CONDUIT BOX LID, NEOP	1.000 EA
10XN2520K16	1/4-20 X 1" HX HD SCRW GRADE 5, ZINC P	4.000 EA
HW1001A25	LOCKWASHER 1/4, ZINC PLT .493 OD, .255 I	4.000 EA
MJ5004A59	ADHESIVE LOCTITE #401 SURFACE INSENSITIV	0.010 EA
HW2501H28	KEY, 1/2 SQ X 3.250	1.000 EA
MJ5002A01	SILICON RUBBER SEALANT, 732CL 10.3 OZ TU	0.025 EA
MJ5001A14	DYNAPRO SEALANT, CP MTR VC#2508050 (603	0.033 EA
MJ5001A27	32220KN GRAY SEALER *MIN BUY 4 QTS=1GAL	0.031 QT
LB1115N	LABEL,LIFTING DEVICE (ON ROLLS)	1.000 EA
WD1000B49	T&B C73,RING TERMINAL 10-12 AWG 3/8 STUD	3.000 EA
10EP1110A139GP6	FR ENDPLATE, MACH W/EPOXY & MG1025N19	1.000 EA
HW4500A21	1618BALEMITE FITTING 825 UNIVERSAL	1.000 EA
HW4500A17	317400 ALEMITE GREASE RELIEF	1.000 EA
HA4051A00	PLASTIC CAP FOR GREASE FITTING	1.000 EA
HA4002A03	#304 S.S. DRAIN FITTING, .125 NPT (.44 H	1.000 EA
MJ1000A62	GREASE - MOBILITH SHC220, HC9455	0.130 LB
HA4051A00	PLASTIC CAP FOR GREASE FITTING	1.000 EA
HW4500A03	GREASE FITTING, .125 NPT 1610(ALEMITE) 8	1.000 EA

Product Information Packet: ECP64104TR-4 - 30HP,1770RPM,3PH,60HZ,286T,1060M,TEFC,F1

HW4500A17	317400 ALEMITE GREASE RELIEF	1.000 EA
HA4002A03	#304 S.S. DRAIN FITTING, .125 NPT (.44 H	1.000 EA
HW2500A25	WOODRUFF KEY USA #1008 #BLOW CARBON STEE	1.000 EA
51XB1214A20	12-14X1.25 HXWSSLD SERTYB	1.000 EA
10FH1007A70GP6	FAN COVER, MACH W/2.00 BORE,EPOXY PRIMER	1.000 EA
MG1025N19	WILKOFAST, 778.50, RELIANCE BLUE-GREEN	0.070 GA
85XU0407S04	4X1/4 U DRIVE PIN STAINLESS	4.000 EA
LB1449	DIV-2/NEC WARNING LABEL	1.000 EA
LB1119N	WARNING LABEL	1.000 EA
LC0006	CONNECTION LABEL	1.000 EA
NP3201	SS IEEE661 INV DIV-2 UL CSA- C US EEV	1.000 EA
12PA1000	PACKAGING GROUP PRINT PK1024A06	1.000 EA
10PA1086	SHAFT TENSIONER 2X4 5-1/4 LEG 4-3/4 OPEN	1.000 EA
10XN5013K48	1/2-13 X 3.00 HEX HD GRADE 5	1.000 EA
HW1000A38	WASHER, 3/8" FLAT, SAE Z/P	1.000 EA
MN416A01	TAG-INSTAL-MAINT no wire (1200/bx) 5/18	1.000 EA

AC Induction Motor Performance Data

Record # 53757 - Typical performance - not guaranteed values

Winding: 10WGZ438-R001	Type: 1060M	Enclosure: TEFC
-------------------------------	--------------------	------------------------

Nameplate Data				460 V, 60 Hz: Single Voltage Motor	
Rated Output (HP)	30			Full Load Torque	88.64 LB-FT
Volts	460			Start Configuration	direct on line
Full Load Amps	36			Breakdown Torque	267 LB-FT
R.P.M.	1770			Pull-up Torque	116 LB-FT
Hz	60	Phase	3	Locked-rotor Torque	142 LB-FT
NEMA Design Code	B	KVA Code	G	Starting Current	215 A
Service Factor (S.F.)	1.15			No-load Current	13.5 A
NEMA Nom. Eff.	93.6	Power Factor	84	Line-line Res. @ 25°C	0.234 Ω
Rating - Duty	40C AMB-CONT			Temp. Rise @ Rated Load	62°C
S.F. Amps				Temp. Rise @ S.F. Load	76°C
				Locked-rotor Power Factor	29.7
				Rotor inertia	4.77 LB-FT ²

Load Characteristics 460 V, 60 Hz, 30 HP

% of Rated Load	25	50	75	100	125	150	S.F.
Power Factor	48	71	80	84	85	85	83
Efficiency	91	94	94.3	94	93.7	92	93.4
Speed	1793	1787	1779	1772	1764	1753	1769
Line amperes	15.8	21.1	27.8	35.6	44	53.5	41.5

Performance Graph at 460V, 60Hz, 30.0HP Typical performance - Not guaranteed values

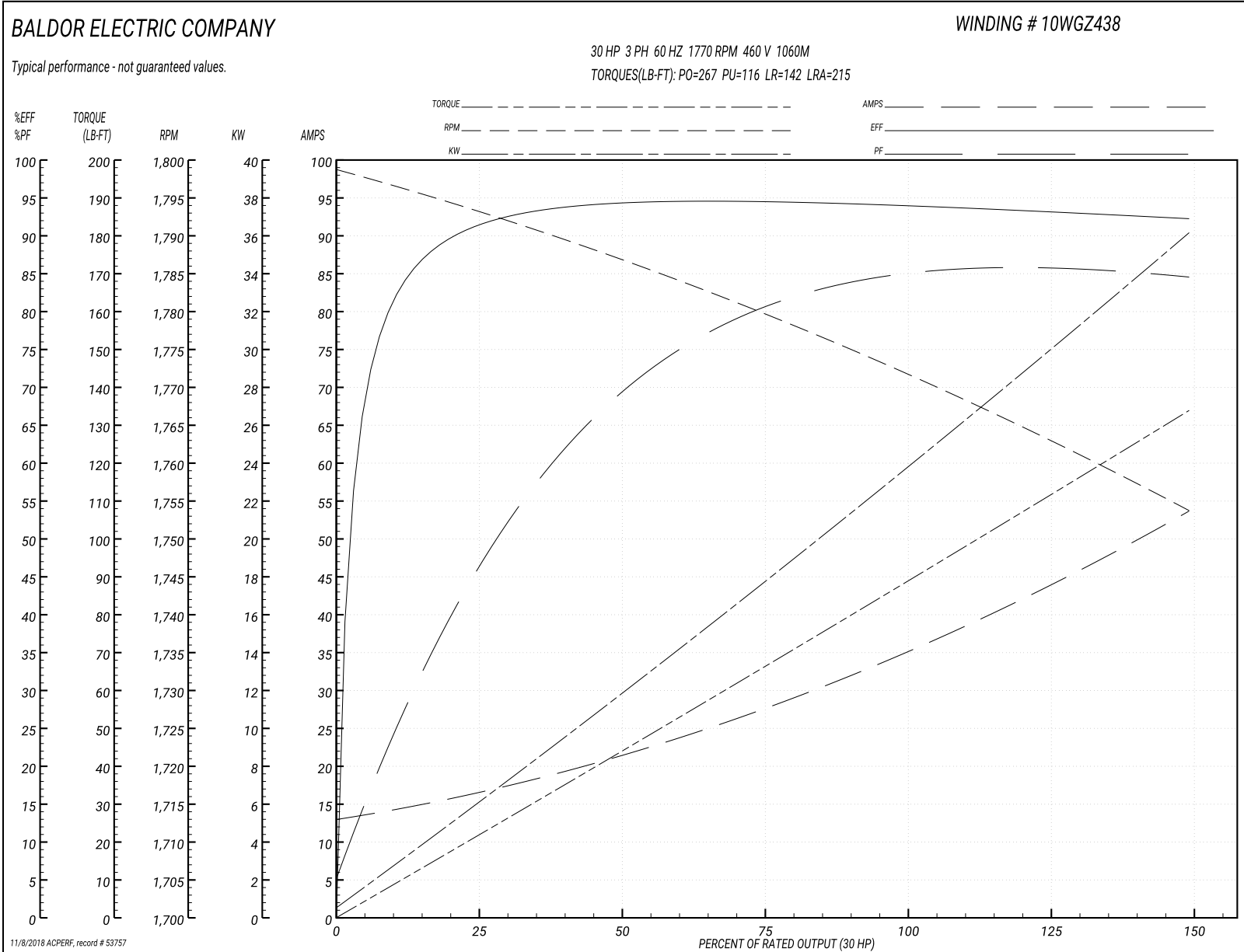

10LYJ448

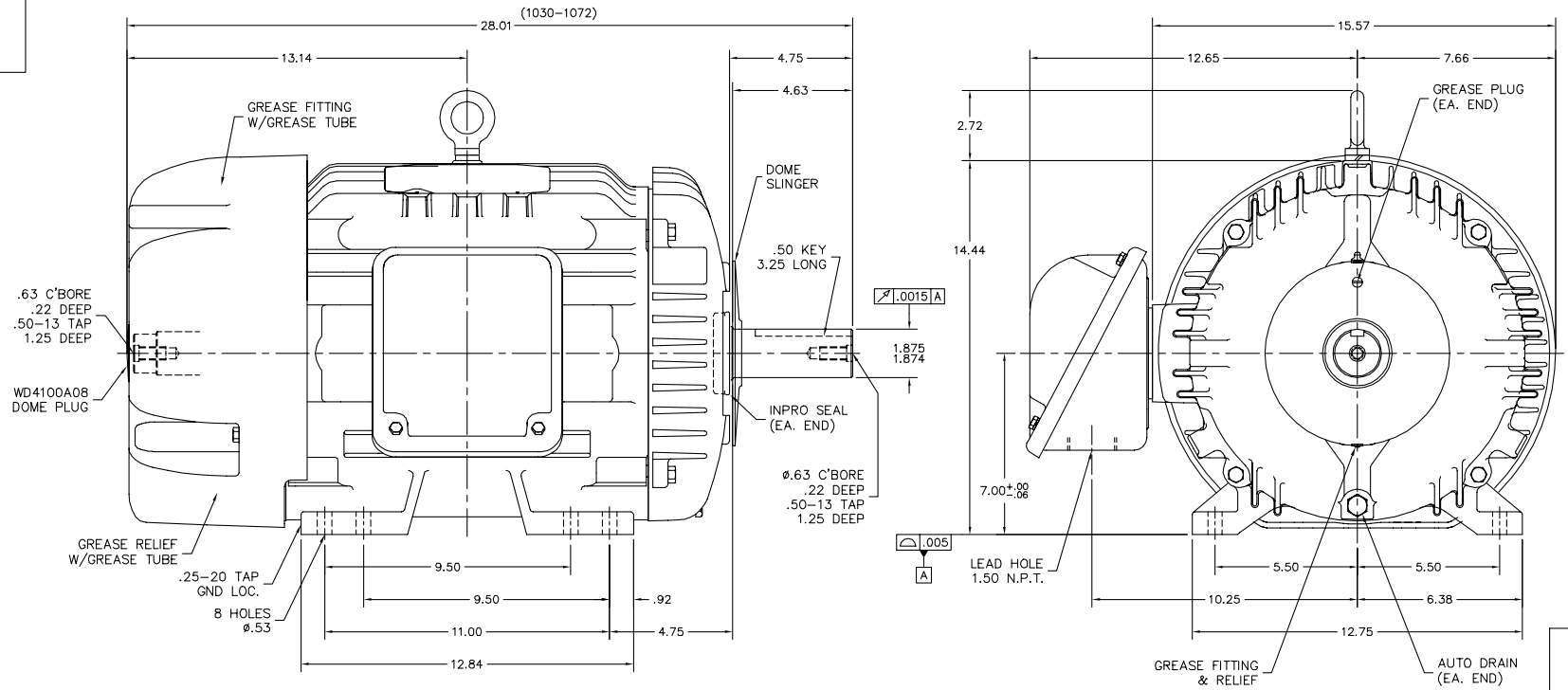

10LYJ448

CUSTOMER IS RESPONSIBLE FOR DETERMINING THAT BALDOR'S PRODUCT WILL PERFORM SUITABLY IN THE INTENDED APPLICATION.

REV. DESC: 10EP1110A139 WAS 10EP1110A123	VERSION: 08	TDR: 000000980223
REV. LTR: H	REvised: 03:42:21 05/16/2016	BY: ENSHABO
FILE: \AAA\00203\562		
MTL: -		

BALDOR

HOR TEFC 284-6T 661XL/841 W/311 BRGS, RLR BRG, DOME SLINGER
SH 1 of 1

CD0006

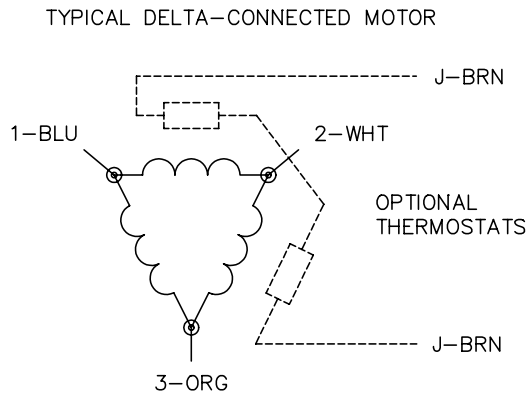
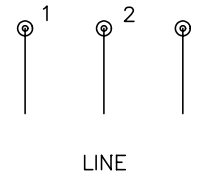
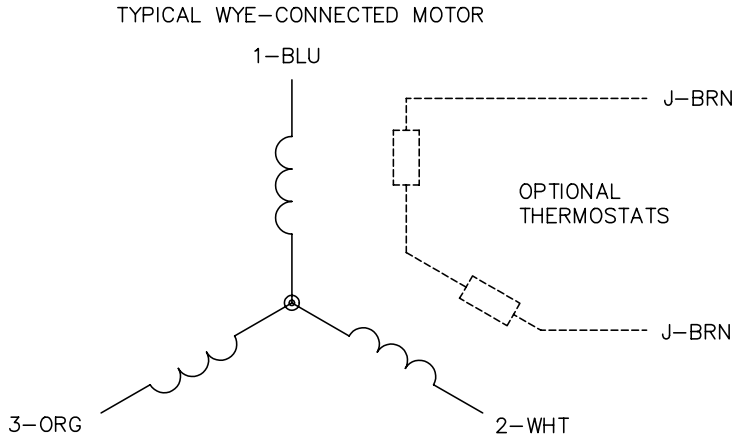

NOTES:

1. THREE LEAD MOTOR MAY BE EITHER WYE CONNECTED OR DELTA CONNECTED.
2. INTERCHANGE ANY TWO LINE LEADS TO REVERSE ROTATION.
3. OPTIONAL THERMOSTATS ARE PROVIDED WHEN SPECIFIED.
4. ACTUAL NUMBER OF INTERNAL PARALLEL CIRCUITS MAY VARY.
5. LEAD COLORS ARE OPTIONAL. LEADS MUST BE NUMBERED AS SHOWN.

REV. DESC: REVISE TO SHOW OPTIONAL COLORS			
REV. LTR: D	BY: JLP	REVISED: 01/21/99 4:02	TDR: 0171435
9000D		FILE: AAA00005141	MDL: -
		MTL: -	

BALDOR ELECTRIC Co.

3PH, SV, 3 LEADS, WYE OR DELTA CONNECTED

CD0006

Marketing maintained PDF of MN416:

<http://www.baldor.com/support/Literature/Load.ashx/MN416?ManNumber=MN416>